

CAD FILE:

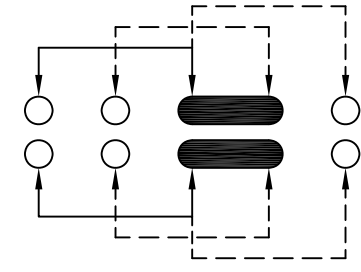

SCHEMATIC (SHORTING)

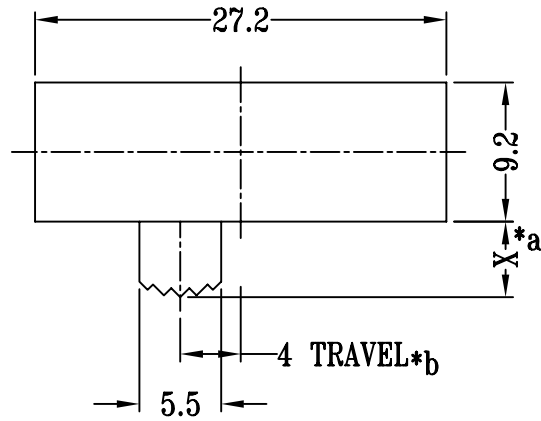
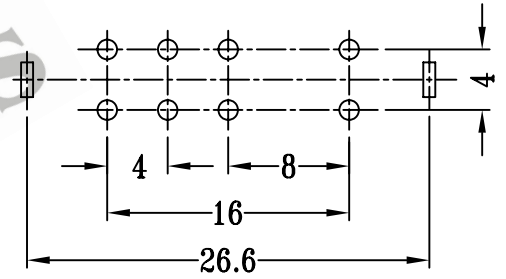
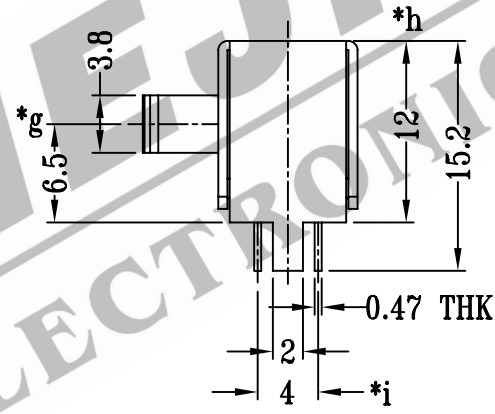
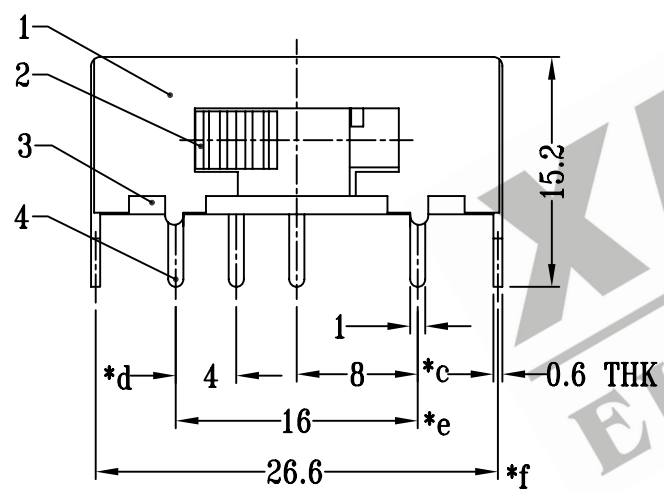

P.C.B LAYOUT

注:带*表示关键尺寸(9个)

NO.	PARTS	MATERIALS	Q'TY	FINISH	TOLERANCE UNLESS SPECIFIED	SHENZHEN XIEJIA ELECTRONICS CO.,LTD.					
8						WITHIN: 1.5±0.1mm OVER: 1.5±0.2mm	ISSUE	DATE	DESCRIPTIONS OF REVISION		APPD
7	CONTACT CLIP	PBS STRIP	2	Ag PLATED							
6	SPRING	STEEL WIRE	1	TEMPER							
5	STEEL BALL	STEEL	1	NATURAL							
4	TERMINAL	BRASS STRIP	8	Ag PLATED OVER Ni PLATED	TITLE: HORIZONTAL SLIDE SWITCH	UNIT: mm	DRWG NO.: XJ-DR-SK23H04-00				
3	BASE	PHENOLIC RESIN	1	BLACK	MODEL: SK-23H04	SCALE: 2:1	DWN	ZHOUYU	2003-12-24		
2	NOB	POM	1	BLACK			CHK'D	FANGYING	2003-12-24		
1	FRAME	STEEL STRIP	1	Ni PLATED			APPD	KANGXINAN	2003-12-24		
					ALL MATERIALS MUST BE COMPLIANT TO ROHS						